

Russell Taylors

E-WARRANTY



SCAN HERE

**STAND MIXER
USER MANUAL**

www.russelltaylors.co.uk



S4

IMPORTANT SAFEGUARDS:

Before using the electric appliance, basic precautions should be always followed as following:

1. Read all instructions.
2. Make sure that your outlet voltage responds to what is stated on the rating label of the mixer.
3. Do not operate the mixer with a damaged cord or plug, after the appliance malfunctions, or if it is dropped or damaged in any manner. Return the appliance to the nearest authorized service center for examination, repair or electrical or mechanical adjustment.
4. Do not leave mixer unattended while it is working.
5. Do not let the cord hang over the edge of table or counter or hot surface.
6. For protecting against the risk of electrical shock, do not put the mixer or power cord in water or other liquids. This may cause personal injury or damage to the product.
7. Avoid contact with moving parts. You're your hands, clothing, as well as spatulas and other utensils away from the beaters during operating to reduce the risk of injury to people, and/or damage to the mixer.
8. Closing supervision is necessary when your appliance is being used near or by children or infirm people.
9. The mixer cannot be used for mixing hard and dry

substance, otherwise the blade could be blunted.

10. This appliance is not intended for being used by people (including children) with reduced physical, sensory or mental capabilities, or lack of experience and knowledge, unless they have been given supervision or instruction concerning the use of the appliance by a person who is responsible for their safety.
11. Children should be supervised to ensure that they do not play with the appliance.
12. Be sure to turn the speed selector to the 0 position after each use.
13. Make sure the motor stops before disassembling and the cord plug is removed from the outlet.
14. Do not place an appliance on or near a hot gas stove or on a heated oven.
15. Never pull out the mixing beater, dough hook or egg whisk while the appliance is in operation.
16. Unplug from the outlet while not in use, before putting on or taking off parts, as well as before cleaning.
17. Do not operate the appliance for other than its intended use.

18. Do not use the appliance outdoor.
19. Save these instructions.
20. The appliance shall not be used by children. Keep the appliance and its cord out of reach of children.
21. Appliances can be used by persons with reduced physical sensory or mental capabilities or lack of experience and knowledge if they have been given supervision or instruction concerning use of the appliance in a safe way and if they understand the hazards involved.
22. Children shall not play with the appliance.
23. Always disconnect the appliance from the supply if it is left unattended and before assembling disassembling or cleaning.
24. Switch off the appliance and disconnect it from the power supply before changing accessories or touching parts that move in use.

IMPORTANT COMPONENTS

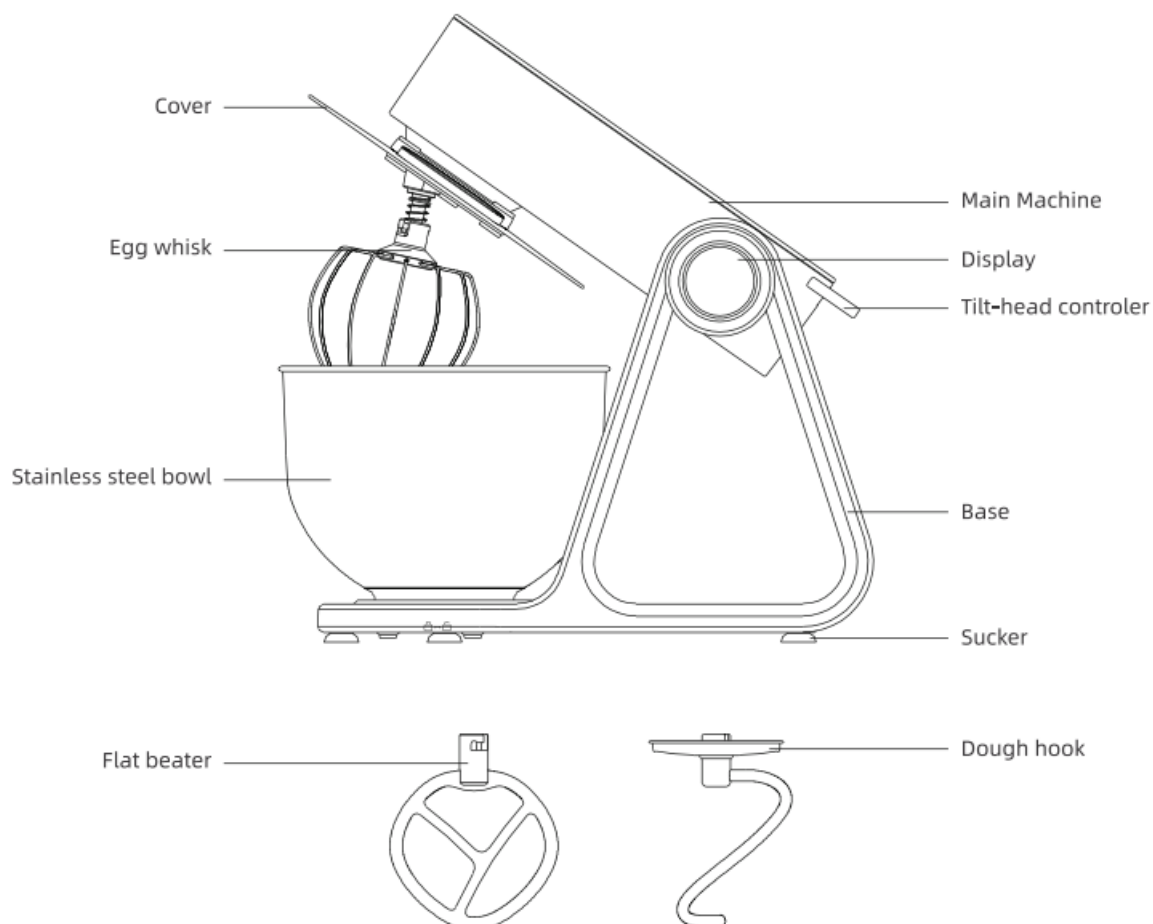

HOW TO CLEAN

1. Please ensure that the power is switched off before cleaning.
2. The appliance needs to be cooled before starting to clean.
3. Use a damp rag and mild detergent to clean the outside of the machine.
4. Do not use abrasive liquid or cloth for cleaning.

HOW TO USE

1. All attachments should be cleaned before use.
2. When the appliance is switched on, the icon will light up.

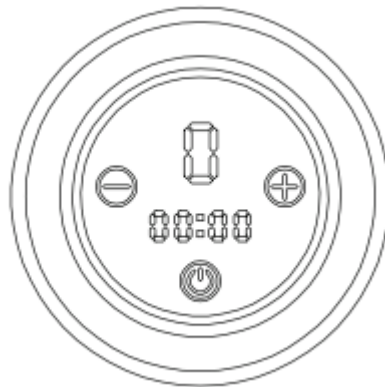

3. There are 6 speed options and the time setting is between 0-10 minutes.

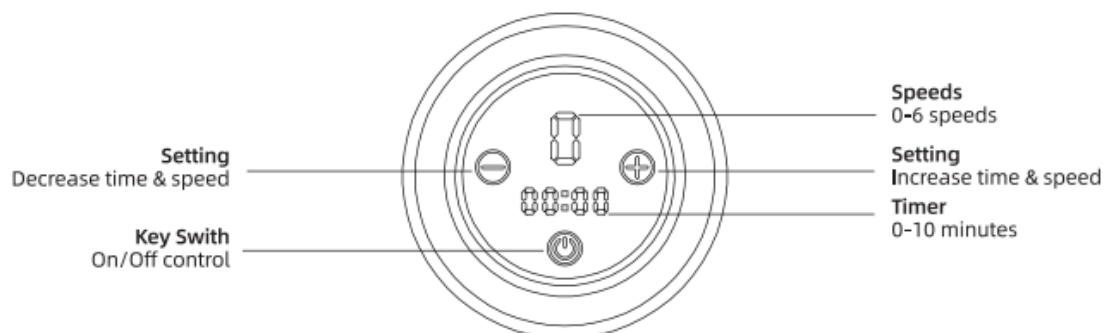

4. Press down the tilt-head controller and the main part of the stand mixer will automatically release and lock to the lifting position.

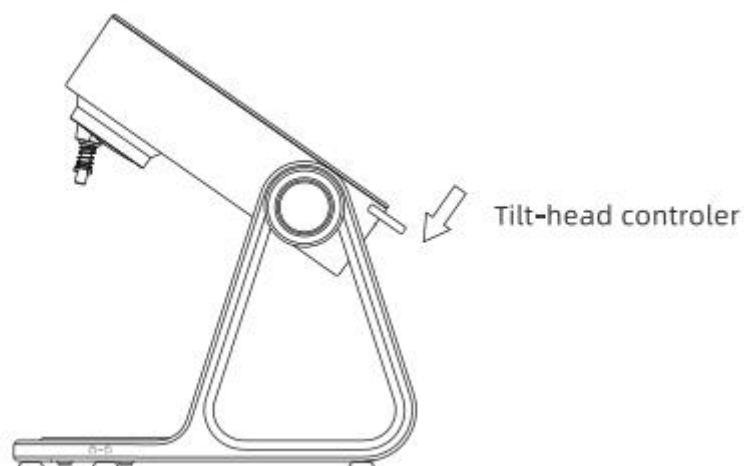

5. Put the splash guard on the stand mixer.

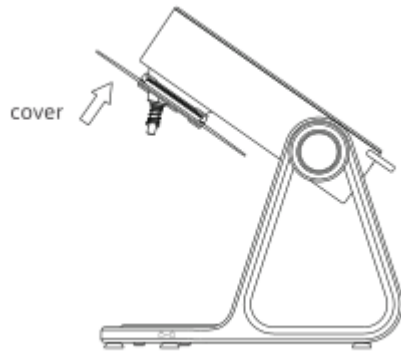

6. Choose the attachments you need.

- a. Flat beater is for mixing cream, milkshakes and others.
- b. Dough hook is for mixing doughs.
- c. The wire whip is for mixing egg whites.

7. Put the attachment into the fixed shaft of the stand mixer.

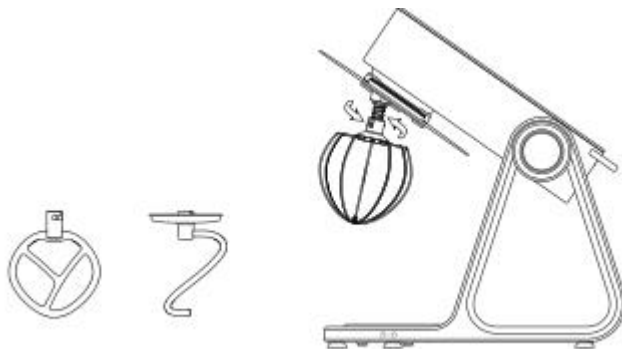

8. The bowl is fixed/removed from the host by turning in the lock/unlock direction as below.



9. Add the ingredients into the stand mixer from the food port of the splash guard.

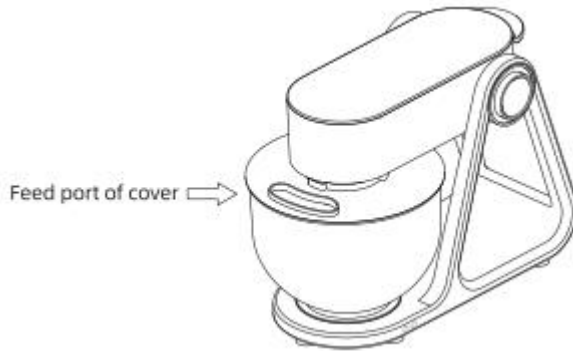

10. The bowl cannot be filled with more than 1000g of flour and 600g of water.
11. If required, you can use a plastic scraper to remove excess food from the flat beater or the dough hook.
12. The max working time shall not exceed 10 minutes each time. Please let the stand mixer rest at least 20 minutes after running 2 cycles.
13. When kneading dough, use speed 1 first and then move up to speed 2 for the best results. Touch the power key when you are done mixing. The speed will go to "0" and then remove the plug from the power supply.